

Revision	Engineering Change Description	Date	Owner
A/0	NEW	2012.08.05	ZXM

Electrical performance	
Characteristic impedance	50 Ω
Frequency range	DC to 6 GHz
Standing wave ratio (VSWR)	$\leq 1.20$ (DC~6GHz)
withstand voltage	$\leq 0.1 \times \sqrt{f}$ (GHz) dB
working voltage	1000 V rms
Test voltage	2500 V rms
Insulation resistance	$\geq 5000M\Omega$
Center pin contact resistance	$\leq 1m\Omega$
Conductor contact resistance	$\leq 1m\Omega$
Center conductor retention force	$\geq 0.56N$
Intermodulation 3rd order	N/A
Mechanical and environment	
Temperature range	-40~+85°C
Salt spray test time	96H
Airtight	N/A
durability	$\geq 500$ cycles
Materials	
Connector parts	Material Plating
Center contact	bronze Ag
Outer contact	brass CuSnZn
Dielectric	PTFE
Seal ring	Red silicone rubber

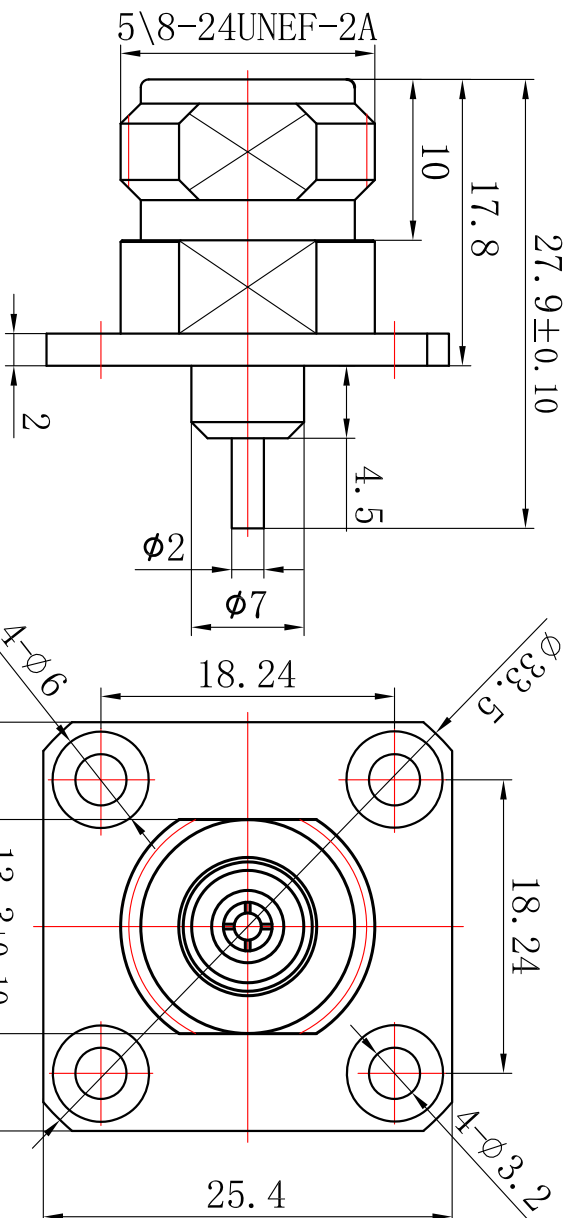

CAD GENERATED DRAWING,  
DO NOT MANUALLY UPDATE

Any statements in this article shall not be interpreted as suggesting infringement of existing patents. Individual values may vary depending on factors including but not limited to application, design, cable type, assembly, and others workmanship

STANDARD TOLERANCES (Unless stated otherwise)

Product design

Geometric tolerances	Positional tolerance		Design
	X	.X	
0-6	$\pm 0.1$	$\pm 0.05$	Drawn
6-10	$\pm 0.1$	$\pm 0.05$	Workmanship
10-30	$\pm 0.15$	$\pm 0.10$	Checked
>30	$\pm 0.15$	$\pm 0.10$	Approvals
Scale:			As mention

 **戴盛通信**  
Dashing Com-Tek Co., Ltd

TITLE: N-50KFD-4.5-5.6

Drawing No.: DS3.650.660

Company website: <http://www.daisheng.net> / Email: [ds168@daisheng.net](mailto:ds168@daisheng.net)