

Reversion	Engineering	Change Description	Date	Owner
A/0		NEW	2019.10.12	ZXM

Electrical performance	
Characteristic impedance	50 Ω
Frequency range	DC to 6 GHz
Standing wave ratio(VSWR)	≤1.20 (DC~6GHz)
withstand voltage	≤0.1 x √f(GHz) dB
working voltage	1000 V rms
Test voltage	2500 V rms
Insulation resistance	≥5000MΩ
Center pin contact resistance	≤1mΩ
Conductor contact resistance	≤1mΩ
Center conductor retention force	≥0.56N
Intermodulation 3rd order	N/A

Mechanical and environment	
Temperature range	-40~+85℃
Salt spray test time	96H
Airtight	N/A
durability	≥500 cycles

Materials		
Connector parts	Material	Plating
Center contact	bronze	Ag
Outer contact	brass	CuSnZn
Dielectric	PTFE	
Seal ring	Red silicone rubber	

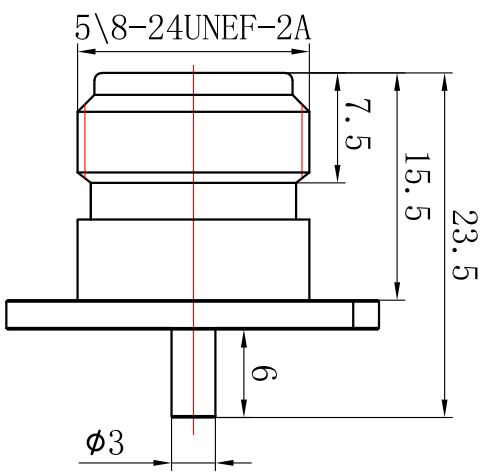
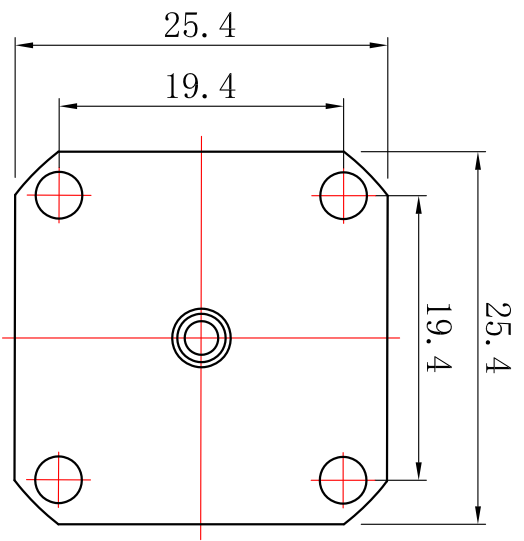

CAD GENERATED DRAWING,
DO NOT MANUALLY UPDATE

STANDARD TOLERANCES (Unless stated otherwise)

Product design

Geometric tolerances	Positional tolerance		Design	Drawn	Workmanship	Checked	Approvals
	X	.X					



戴盛通信
Dashing Com-Tek Co., Ltd

TITLE:

N-50KFD--6

Drawing No.:

DS3.650.2037

Any statements in this article shall not be interpreted as suggesting infringement of existing patents. Individual values may vary depending on factors including but not limited to application, design, cable type, assembly, and others workmanship

Scale:

0-6	±0.1	±0.05
6-10	±0.1	±0.05
10-30	±0.15	±0.10
>30	±0.15	±0.10

As mension	
------------	--

Company website: <http://www.dai.sheng.net> / Email: ds168@dai.sheng.net